



**SLIDING AXLE SUSPENSION**

**50SA140426**



## **SLIDING AXLE SUSPENSION**

3 AXLE, FIXED NECK,  
MAXIMUM PAYLOAD 100,000 LBS



# SLIDING AXLE

## Features & Benefits



### Winch System



Available options for 12,000 to 30,000 lb hydraulic winch system. Mounted front and center of the upper deck. Standard cable length of 85' with shackle. Cable length options are available.

### Hydraulic Controls

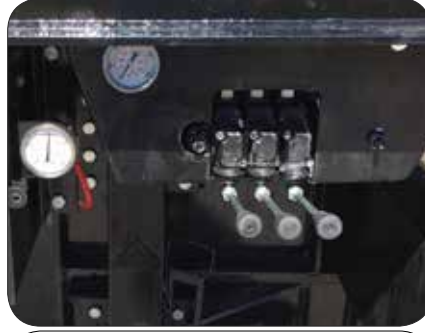

Controls located on the driver side of the upper deck.

### Sliding Axle



Will handle heavy loads with a super low angle while maintaining superior stability during loading and unloading.

### Head Rack Option



Optional detachable steel bulkhead, 48" high with optional work lights.

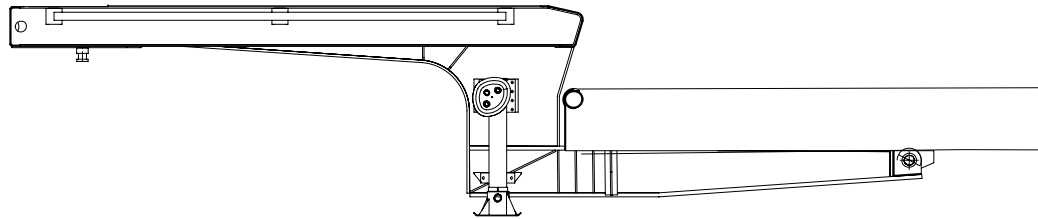

### Air Bags



30,000 pound rated large diameter air bags are standard. This allows for lower operating pressure and higher capacity when needed.

### Decking Options



**Oak:** Standard.  
**Apitong:** Best strength to weight ratios of natural woods.  
**Rumber:** Composite which is impervious to fluids, mud, oil and UV rays.

### Wheel Options



All Globe trailers come with standard HUB piloted disc wheels. Wheels are also available in all Aluminum or Outer Aluminum.

# SLIDING AXLE

## Features & Benefits



### STEMCO Wheel Warranty



5 year wheel end warranty. Guardian wheel seals, Pro-Torq spindle nuts and Sentinel hub caps.

### Color Options



Globe Trailers can powder coat to the color of your choice

### Lighting System



All Lighting is LED and mounted in rubber grommets to DOT standards.

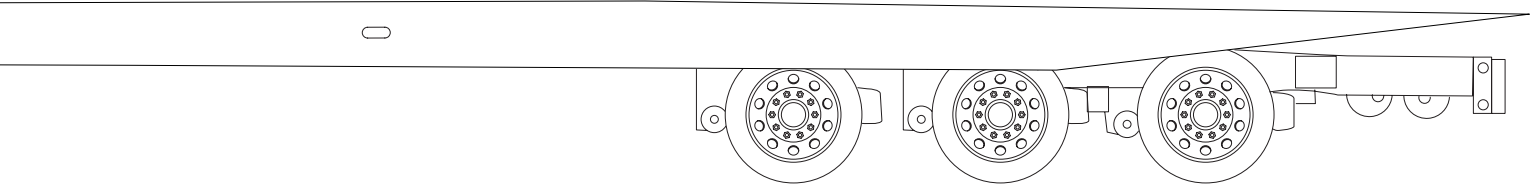

All Globe Trailers are 100% powder coat finished. The entire process takes place at Globe's manufacturing facility. This eliminates the possibility of contamination occurring in transit between process phases. The process starts with sandblasting the trailer to near white, preheating the trailer steel in a dedicated, gas fired oven to optimum bonding temperature and applying an electrostatically charged zinc rich primer. The trailer then goes back in the oven to allow the primer to bond. After the primer has bonded, a top coat chosen from one of Globe Trailers' 188 color options is applied before once more going back in the oven to cure. The result is a durable, easily cleaned finish that protects the trailer from corrosion and ensures a long service life.

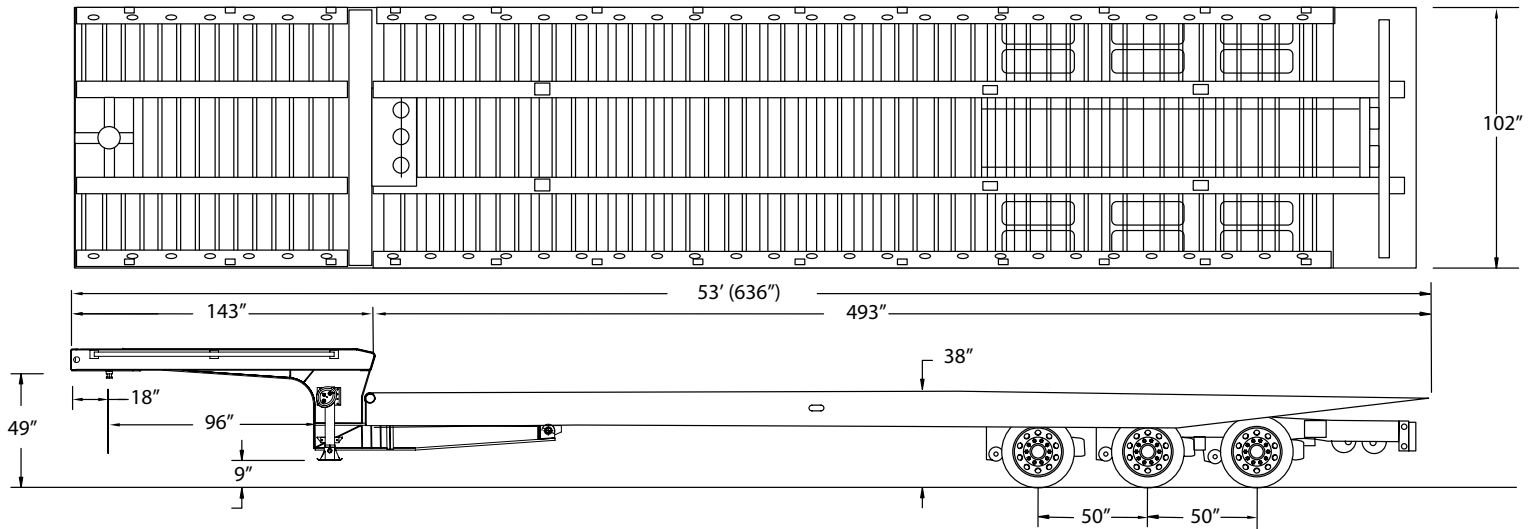

Overall Length	Overall Width	Gooseneck Length	Lower Deck Length	Lower Deck Height	Swing Clearance	5th Wheel Height	Ground Clearance
53' (636")	8' 6" (102")	11' 11" (143")	41' 1" (493")	38"	96"	49"	9"

Main Deck	
Main Beam	14" T-1 Steel
Centers	38"
Side Rails	15" T-1 Steel
Crossmembers	4"
Spacing	9"
Stake Pockets	48" Centers w/ rubrail
Single Key-hole Slots	On the sides and double on center of load well deck
Tool Boxes	(2) Tool boxes in upper deck with lockable covers
Decking/Flooring	
Main Decking	1 3/4" (Apitong or Oak)
Well Decking	Full Deck
Electrical	
Lights	LED Plus 2 - Rear Strobes
Optional work lights that can be mounted to the header.	
Connector	7 Way SAE Connector
Tires & Rims	
Tires	235/75R X 17.5 "H"
Rims	6.75 X 17.5 Hub Piloted Outer Aluminum
Finish	
Sandblast & Powder Coat (Black)	
Mud Flaps & Reflective Tape	
Flag Holders	
Hydraulics	
Wet line to truck with quick couplers.	
27 HP Pony Motor Optional	

Axles, Suspension, & Running Gear	
# of Axles	3
Axle Spacing	50"
Axle Capacity	25,000lbs
Axle Track	71 1/2"
Brakes	16 1/2" x 7" - 25K
ABS	2S1M
Axle 1	Fixed Type 30/30 Non-ABS
Axle 2	Fixed Type 30/30 Non-ABS
Axle 3	Fixed Type 30 ABS
Ridewell Air Ride Suspension.	
Manual Dump Valve	
Gooseneck	
King Pin Style	Fixed
King Pin Setting	18"
Swing Clearance	96"
5th Wheel Height	49"
King Pin	2"

**Dealer:**